

SIRIUS SAFETY RELAY BASIC UNIT ADVANCED SERIES RELAY
 ENABLING CIRCUITS 3 NO CONTACTS + RELAY SIGNALING
 CIRCUIT 1 NC CONTACT US = 24 V DC SPRING-LOADED
 TERMINAL



Figure similar

| General technical data: | |
|---|------------------------------------|
| product brand name | SIRIUS |
| Product designation | safety relays |
| Design of the product | For autonomous safety applications |
| Protection class IP of the enclosure | IP20 |
| Protection against electrical shock | finger-safe |
| Insulation voltage Rated value | 300 V |
| Ambient temperature | |
| • during storage | -40 ... +80 °C |
| • during operation | -25 ... +60 °C |
| Air pressure acc. to SN 31205 | 90 ... 106 kPa |
| Relative humidity during operation | 10 ... 95 % |
| Installation altitude at height above sea level maximum | 2 000 m |
| Vibration resistance acc. to IEC 60068-2-6 | 5 ... 500 Hz: 0,75 mm |
| Shock resistance | 10g / 11 ms |
| Surge voltage resistance Rated value | 4 000 V |
| EMC emitted interference | IEC 60947-5-1, Class A |

| | |
|---|--|
| Installation environment regarding EMC | This product is suitable for Class A environments only. It can cause undesired radio-frequency interference in residential environments. If this is the case, the user must take appropriate measures. |
| Overvoltage category | Installation category III |
| Degree of pollution | 3 |
| Number of sensor inputs 1-channel or 2-channel | 1 |
| Design of the cascading | yes |
| Type of the safety-related wiring of the inputs | single-channel and two-channel |
| Product property cross-circuit-proof | Yes |
| Safety Integrity Level (SIL) • acc. to IEC 61508 | SIL3 |
| Performance level (PL) • acc. to EN ISO 13849-1 | e |
| Category acc. to EN ISO 13849-1 | 4 |
| Safe failure fraction (SFF) | 99 % |
| PFHD with high demand rate acc. to EN 62061 | 0.0000000025 1/h |
| Average probability of failure on demand (PFDavg) with low demand rate acc. to IEC 61508 | 0.000007 1/y |
| T1 value for proof test interval or service life acc. to IEC 61508 | 20 y |
| Hardware fault tolerance acc. to IEC 61508 | 1 |
| Safety device type acc. to IEC 61508-2 | Type B |
| Number of outputs as contact-affected switching element | |
| • as NC contact | |
| — for signaling function instantaneous contact | 1 |
| — for signaling function delayed switching | 0 |
| — safety-related instantaneous contact | 0 |
| — safety-related delayed switching | 0 |
| • as NO contact | |
| — for signaling function instantaneous contact | 0 |
| — for signaling function delayed switching | 0 |
| — safety-related instantaneous contact | 3 |
| Number of outputs as contact-less semiconductor switching element | |
| • safety-related | |
| — delayed switching | 0 |
| — instantaneous contact | 0 |
| • for signaling function instantaneous contact | 0 |
| Stop category acc. to DIN EN 60204-1 | 0 |

General technical data:

| | |
|--|---|
| Design of input | |
| <ul style="list-style-type: none"> • cascading input/functional switching • feedback input • Start input | <p>Yes</p> <p>Yes</p> <p>Yes</p> |
| Type of electrical connection Plug-in socket | No |
| Operating frequency maximum | 360 1/h |
| Switching capacity current | |
| <ul style="list-style-type: none"> • of the NO contacts of the relay outputs <ul style="list-style-type: none"> — at DC-13 <ul style="list-style-type: none"> — at 24 V — at 115 V — at 230 V — at AC-15 <ul style="list-style-type: none"> — at 115 V — at 230 V • of the NC contacts of the relay outputs <ul style="list-style-type: none"> — at DC-13 <ul style="list-style-type: none"> — at 24 V — at 115 V — at 230 V — at AC-15 <ul style="list-style-type: none"> — at 115 V — at 230 V | <p>5 A</p> <p>0.2 A</p> <p>0.1 A</p> <p>5 A</p> <p>5 A</p> <p>1 A</p> <p>0.2 A</p> <p>0.1 A</p> <p>1.5 A</p> <p>1.5 A</p> |
| Thermal current of the switching element with contacts maximum | 5 A |
| Operating current at 17 V minimum | 5 mA |
| Mechanical service life (switching cycles) typical | 10 000 000 |
| Design of the fuse link for short-circuit protection of the NO contacts of the relay outputs required | gL/gG: 6A or circuit breaker type A: 3A or circuit breaker type B: 2A or circuit breaker type C: 1A |
| Design of the fuse link for short circuit protection of the NC contacts of the relay outputs required | Diazed or Neozed fuses, operating class gL/gG: 6 A or MCB type A: 2 A or MCB type B: 2 A or MCB type C: 1 A |
| Cable length | |
| <ul style="list-style-type: none"> • with Cu 1.5 mm² and 150 nF/km per sensor circuit maximum | 4 000 m |
| Make time with automatic start | |
| <ul style="list-style-type: none"> • at DC maximum | 110 ms |
| Make time with automatic start after power failure | |
| <ul style="list-style-type: none"> • typical • maximum | <p>6 500 ms</p> <p>6 500 ms</p> |
| Make time with monitored start | |
| <ul style="list-style-type: none"> • maximum | 110 ms |

| | |
|--|--------|
| Backslide delay time after opening of the safety circuits typical | 40 ms |
| Backslide delay time in the event of power failure | |
| • typical | 30 ms |
| • maximum | 50 ms |
| Recovery time after opening of the safety circuits typical | 30 ms |
| Recovery time after power failure typical | 6.5 s |
| Pulse duration | |
| • of the sensor input minimum | 75 ms |
| • of the ON pushbutton input minimum | 0.15 s |

Control circuit/ Control:

| | |
|---|-------------|
| Type of voltage of the control supply voltage | DC |
| Control supply voltage | |
| • at DC | |
| — Rated value | 24 V |
| Operating range factor control supply voltage rated value of the magnet coil | |
| • at DC | 0.8 ... 1.2 |
| Active power loss typical | 2 W |

Installation/ mounting/ dimensions:

| | |
|--|----------------------------|
| mounting position | any |
| Required spacing for grounded parts at the side | 5 mm |
| Required spacing with side-by-side mounting at the side | 0 mm |
| Mounting type | screw and snap-on mounting |
| Width | 22.5 mm |
| Height | 100 mm |
| Depth | 121.6 mm |





Connections/ Terminals:

| | |
|---|--|
| Type of electrical connection | spring-loaded terminals |
| Type of connectable conductor cross-section | |
| • solid | 1x (0.5 ... 1.5 mm ²), 2x (0.5 ... 1.5 mm ²) |
| • finely stranded | |
| — with core end processing | 1x (0.5 ... 1.0 mm ²), 2x (0.5 ... 1.0 mm ²) |
| — without core end processing | 1x (0.5 ... 1.5 mm ²), 2x (0.5 ... 1.5 mm ²) |
| Type of connectable conductor cross-section for AWG conductors | |
| • solid | 1x (20 ... 16), 2x (20 ... 16) |
| • stranded | 1x (20 ... 16), 2x (20 ... 16) |

Product Function:

| | |
|---|--|
| Product function parameterizable | Sensor floating / sensor non-floating, monitored start / autostart, 1-channel / 2-channel sensor connection, cross-circuit detection, startup testing, antivalent sensors, 2-hand switches |
| Suitability for operation Device connector 3ZY12 | Yes |
| Suitability for interaction press control | Yes |
| Suitability for use | |
| • safety switch | Yes |
| • Monitoring of floating sensors | Yes |
| • Monitoring of non-floating sensors | Yes |
| • magnetically operated switch monitoring | Yes |
| • safety-related circuits | Yes |

Certificates/ approvals:

| General Product Approval | EMC | Functional Safety/Safety of Machinery | Declaration of Conformity |
|--|---|--|---|
|  CCC |  C-TICK | Baumusterbescheinigung |  EG-Konf. |
|  CSA |  UL | | |

| | |
|--------------------------|--------------|
| Test Certificates | other |
|--------------------------|--------------|

[Typprüfbescheinigung/Werkszeugnis](#)

[Bestätigungen](#)

Further information

Information- and Downloadcenter (Catalogs, Brochures,...)

<http://www.siemens.com/industrial-controls/catalogs>

Industry Mall (Online ordering system)

<http://www.siemens.com/industrymall>

Cax online generator

<http://support.automation.siemens.com/WW/CAXorder/default.aspx?lang=en&mfb=3SK11212AB40>

Service&Support (Manuals, Certificates, Characteristics, FAQs,...)

<https://support.industry.siemens.com/cs/ww/en/ps/3SK11212AB40>

Image database (product images, 2D dimension drawings, 3D models, device circuit diagrams, EPLAN macros, ...)

http://www.automation.siemens.com/bilddb/cax_de.aspx?mfb=3SK11212AB40&lang=en

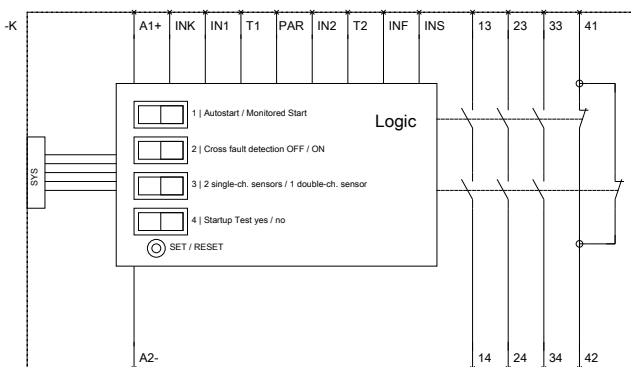
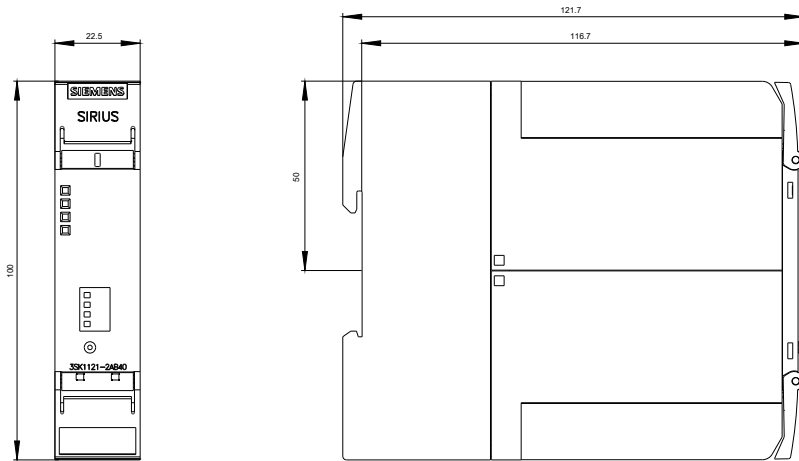

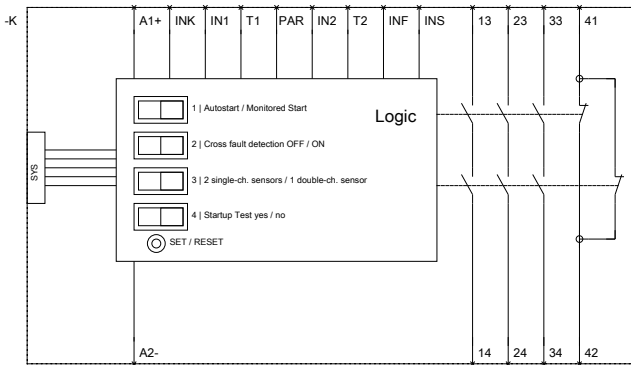

last modified:

20.07.2015