

SIRIUS safety relay Basic unit Standard series electronic enabling circuits 2 enabling circuits plus 1 signaling circuit $U_s = 24\text{ V DC}$ screw terminal



Figure similar

General technical data	
Product brand name	SIRIUS
Product category	Safety relays
Product designation	safety relays
Protection class IP of the enclosure	IP20
Protection against electrical shock	finger-safe
Insulation voltage rated value	50 V
Ambient temperature	
• during storage	-40 ... +80 °C
• during operation	-25 ... +60 °C
Air pressure acc. to SN 31205	90 kPa ... 106 kPa
Relative humidity during operation	10 ... 95 %
Installation altitude at height above sea level maximum	2 000 m
Vibration resistance acc. to IEC 60068-2-6	5 ... 500 Hz: 0.75 mm
Shock resistance	10g / 11 ms
Surge voltage resistance rated value	800 V
EMC emitted interference	IEC 60947-5-1, Class A

Installation environment regarding EMC	This product is suitable for Class A environments only. It can cause undesired radio-frequency interference in residential environments. If this is the case, the user must take appropriate measures.
Overvoltage category	3
Degree of pollution	3
Number of sensor inputs 1-channel or 2-channel	1
Design of the cascading	yes
Type of the safety-related wiring of the inputs	single-channel and two-channel
Product feature cross-circuit-proof	Yes
Safety Integrity Level (SIL)	
• acc. to IEC 61508	3
Performance level (PL)	
• acc. to EN ISO 13849-1	e
Category acc. to EN ISO 13849-1	4
Safe failure fraction (SFF)	99 %
PFHD with high demand rate acc. to EN 62061	0.000000001 1/h
PFDAvg with low demand rate acc. to IEC 61508	0.000007
T1 value for proof test interval or service life acc. to IEC 61508	20 y
Hardware fault tolerance acc. to IEC 61508	1
Safety device type acc. to IEC 61508-2	Type B
Number of outputs as contact-affected switching element	
• as NC contact	
— for signaling function instantaneous contact	0
— for signaling function delayed switching	0
— safety-related instantaneous contact	0
— safety-related delayed switching	0
• as NO contact	
— for signaling function instantaneous contact	0
— for signaling function delayed switching	0
— safety-related instantaneous contact	0
— safety-related delayed switching	0
Number of outputs as contact-less semiconductor switching element	
• safety-related	
— delayed switching	0
— instantaneous contact	2
• for signaling function instantaneous contact	1
Stop category acc. to DIN EN 60204-1	0

General technical data

Design of input	
<ul style="list-style-type: none"> • cascading input/functional switching • feedback input • Start input 	<p>Yes</p> <p>Yes</p> <p>Yes</p>
Type of electrical connection Plug-in socket	No
Operating frequency maximum	2 000 1/h
Switching capacity current	
<ul style="list-style-type: none"> • of semiconductor outputs at DC-13 at 24 V 	2 A
Design of the fuse link for short-circuit protection of the NO contacts of the relay outputs required	not required
Wire length	
<ul style="list-style-type: none"> • with Cu 1.5 mm² and 150 nF/km per sensor circuit maximum 	4 000 m
Make time with automatic start	
<ul style="list-style-type: none"> • at DC maximum 	85 ms
Make time with automatic start after power failure	
<ul style="list-style-type: none"> • typical • maximum 	<p>6 500 ms</p> <p>6 500 ms</p>
Make time with monitored start	
<ul style="list-style-type: none"> • maximum 	85 ms
Backslide delay time after opening of the safety circuits typical	40 ms
Backslide delay time in the event of power failure	
<ul style="list-style-type: none"> • typical • maximum 	<p>0 ms</p> <p>0 ms</p>
Recovery time after opening of the safety circuits typical	30 ms
Recovery time after power failure typical	6.5 s
Pulse duration	
<ul style="list-style-type: none"> • of the sensor input minimum • of the ON pushbutton input minimum 	<p>60 ms</p> <p>0.15 s</p>

Control circuit/ Control

Type of voltage of the control supply voltage	DC
Control supply voltage	
<ul style="list-style-type: none"> • at DC <ul style="list-style-type: none"> — rated value 	24 V
Operating range factor control supply voltage rated value of magnet coil	
<ul style="list-style-type: none"> • at DC 	0.8 ... 1.2
Power loss [W] typical	2 W

Installation/ mounting/ dimensions

Mounting position	any
Required spacing for grounded parts at the side	5 mm
Required spacing with side-by-side mounting at the side	0 mm
Mounting type	screw and snap-on mounting
Width	22.5 mm
Height	100 mm
Depth	91.6 mm

Connections/Terminals

Type of electrical connection	screw-type terminals
Type of connectable conductor cross-sections	1x (0.5 ... 2.5 mm ²), 2x (1.0 ... 1.5 mm ²)
<ul style="list-style-type: none"> • solid • finely stranded — with core end processing 	1x (0.5 ... 2.5 mm ²), 2x (0.5 ... 1.0 mm ²)
Type of connectable conductor cross-sections at AWG conductors	
<ul style="list-style-type: none"> • solid • stranded 	1x (20 ... 14), 2x (18 ... 16) 1x (20 ... 16), 2x (20 ... 16)

Product Function

Product function parameterizable	Sensor floating / sensor non-floating, monitored start / autostart, 1-channel / 2-channel sensor connection, cross-circuit detection, startup testing
Suitability for operation Device connector 3ZY12	No
Suitability for interaction press control	No
Suitability for use	
<ul style="list-style-type: none"> • safety switch • Monitoring of floating sensors • Monitoring of non-floating sensors • magnetically operated switch monitoring • safety-related circuits 	Yes Yes Yes Yes Yes

Certificates/approvals

General Product Approval	EMC	Functional Safety/Safety of Machinery
--------------------------	-----	---------------------------------------



[Type Examination](#)

Declaration of Conformity	Test Certificates	Shipping Approval	other
---------------------------	-------------------	-------------------	-------



[Type Test Certificates/Test Report](#)



[Confirmation](#)

Railway

[Confirmation](#)

Further information

Information- and Downloadcenter (Catalogs, Brochures,...)

<http://www.siemens.com/industrial-controls/catalogs>

Industry Mall (Online ordering system)

<https://mall.industry.siemens.com/mall/en/en/Catalog/product?mlfb=3SK1112-1BB40>

Cax online generator

<http://support.automation.siemens.com/WW/CAXorder/default.aspx?lang=en&mlfb=3SK1112-1BB40>

Service&Support (Manuals, Certificates, Characteristics, FAQs,...)

<https://support.industry.siemens.com/cs/ww/en/ps/3SK1112-1BB40>

Image database (product images, 2D dimension drawings, 3D models, device circuit diagrams, EPLAN macros, ...)

http://www.automation.siemens.com/bilddb/cax_de.aspx?mlfb=3SK1112-1BB40&lang=en

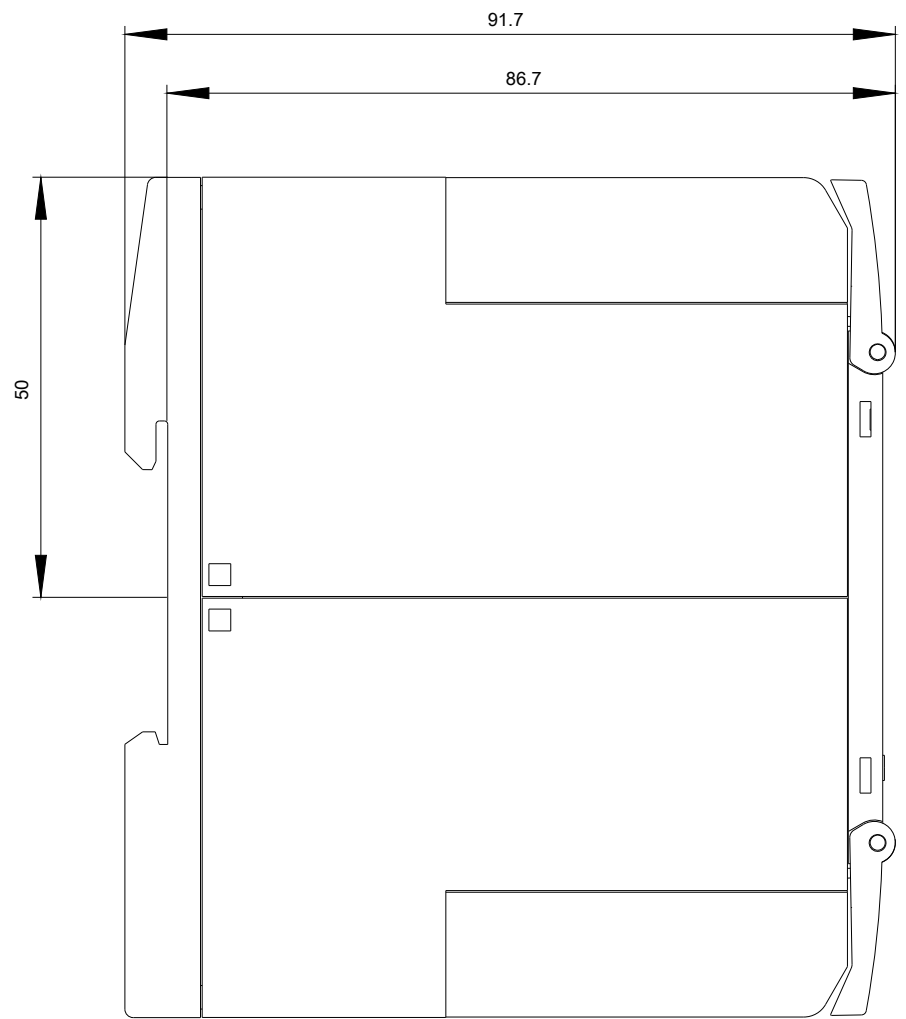
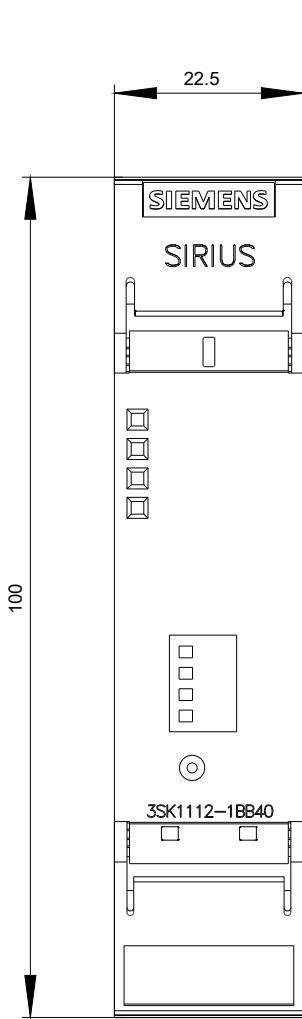

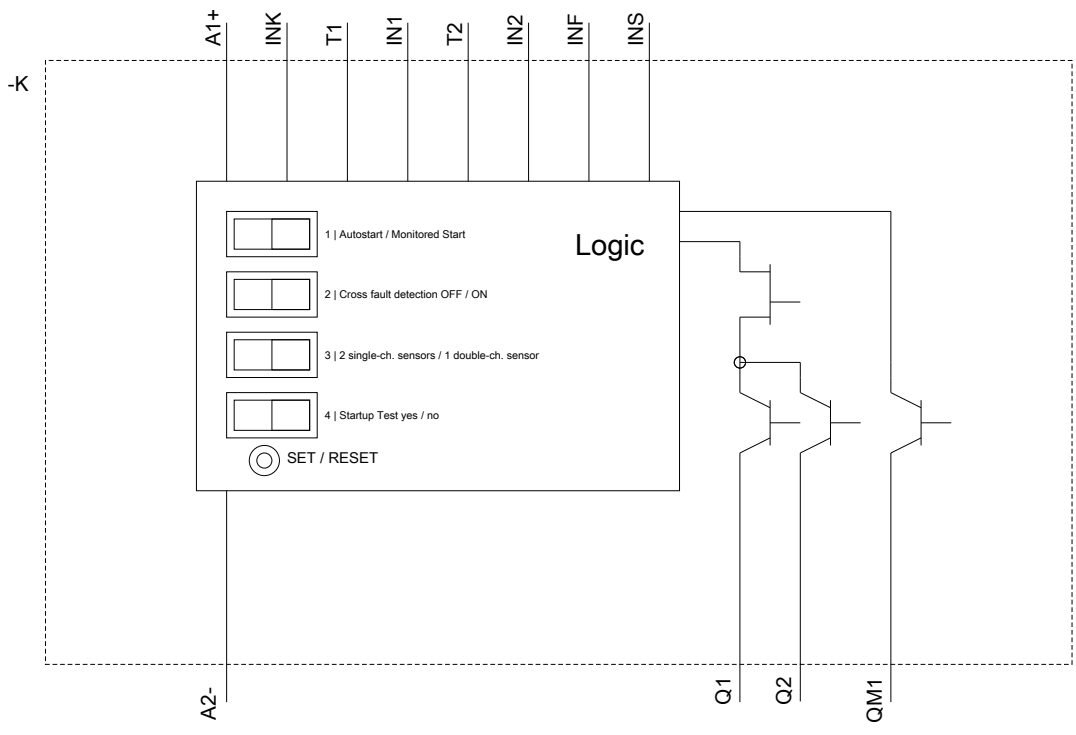

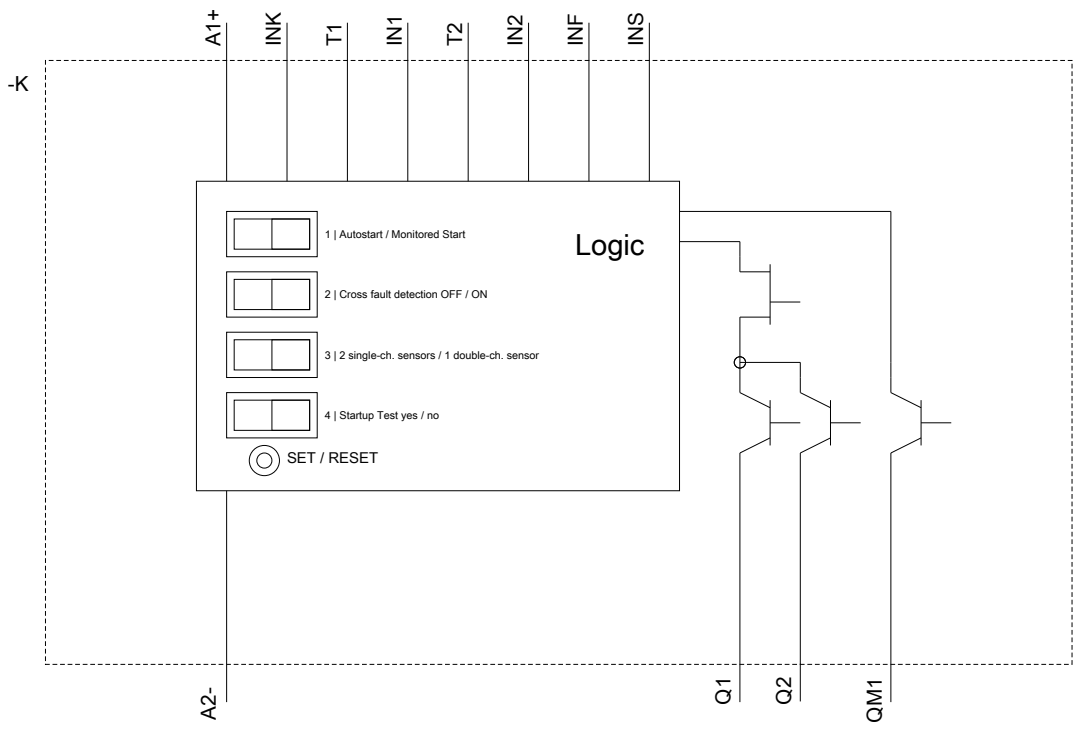

last modified:

04/29/2018