



Figure similar

SIRIUS soft starter 200-480 V 210 A, 24 V AC/DC Spring-loaded terminals  
Analog output

<b>product brand name</b>	SIRIUS
<b>product category</b>	Hybrid switching devices
<b>product designation</b>	Soft starter
<b>product type designation</b>	3RW50
<b>manufacturer's article number</b>	
<ul style="list-style-type: none"> <li>• of standard HMI module usable</li> </ul>	3RW5980-OHS01
<ul style="list-style-type: none"> <li>• of high feature HMI module usable</li> </ul>	3RW5980-OHF00
<ul style="list-style-type: none"> <li>• of communication module PROFINET standard usable</li> </ul>	3RW5980-OCS00
<ul style="list-style-type: none"> <li>• of communication module PROFIBUS usable</li> </ul>	3RW5980-OCP00
<ul style="list-style-type: none"> <li>• of communication module Modbus TCP usable</li> </ul>	3RW5980-OCT00
<ul style="list-style-type: none"> <li>• of communication module Modbus RTU usable</li> </ul>	3RW5980-OCR00
<ul style="list-style-type: none"> <li>• of communication module Ethernet/IP</li> </ul>	3RW5980-OCE00
<ul style="list-style-type: none"> <li>• of circuit breaker usable at 400 V</li> </ul>	3VA2440-7MN32-0AA0; Type of assignment 1, I <sub>q</sub> = 65 kA
<ul style="list-style-type: none"> <li>• of circuit breaker usable at 500 V</li> </ul>	3VA2440-7MN32-0AA0; Type of assignment 1, I <sub>q</sub> = 65 kA
<ul style="list-style-type: none"> <li>• of the gG fuse usable up to 690 V</li> </ul>	2x3NA3354-6; Type of coordination 1, I <sub>q</sub> = 65 kA
<ul style="list-style-type: none"> <li>• of full range R fuse link for semiconductor protection usable up to 690 V</li> </ul>	3NE1 230-2; Type of coordination 2, I <sub>q</sub> = 65 kA
<ul style="list-style-type: none"> <li>• of back-up R fuse link for semiconductor protection usable up to 690 V</li> </ul>	3NE3 333; Type of coordination 2, I <sub>q</sub> = 65 kA
<ul style="list-style-type: none"> <li>• of line contactor usable up to 480 V</li> </ul>	3RT1064
<ul style="list-style-type: none"> <li>• of line contactor usable up to 690 V</li> </ul>	3RT1064
<b>General technical data</b>	
<b>starting voltage [%]</b>	30 ... 100 %
<b>stopping voltage [%]</b>	50 ... 50 %
<b>start-up ramp time of soft starter</b>	0 ... 20 s
<b>ramp-down time of soft starter</b>	0 ... 20 s
<b>current limiting value [%] adjustable</b>	130 ... 700 %
<b>accuracy class acc. to IEC 61557-12</b>	5 %
<b>certificate of suitability</b>	
<ul style="list-style-type: none"> <li>• CE marking</li> </ul>	Yes
<ul style="list-style-type: none"> <li>• UL approval</li> </ul>	Yes
<ul style="list-style-type: none"> <li>• CSA approval</li> </ul>	Yes
<b>product component is supported</b>	
<ul style="list-style-type: none"> <li>• HMI-Standard</li> </ul>	Yes
<ul style="list-style-type: none"> <li>• HMI-High Feature</li> </ul>	Yes
<b>product feature integrated bypass contact system</b>	Yes
<b>number of controlled phases</b>	2

<b>trip class</b>	CLASS 10A / 10E (preset) / 20E; acc. to IEC 60947-4-2
<b>buffering time in the event of power failure</b>	
• for main current circuit	100 ms
• for control circuit	100 ms
insulation voltage rated value	600 V
<b>degree of pollution</b>	3, acc. to IEC 60947-4-2
<b>impulse voltage rated value</b>	6 kV
<b>blocking voltage of the thyristor maximum</b>	1 600 V
<b>service factor</b>	1
<b>reference code acc. to IEC 81346-2</b>	Q
<b>product function</b>	
• ramp-up (soft starting)	Yes
• ramp-down (soft stop)	Yes
• Soft Torque	Yes
• adjustable current limitation	Yes
• pump ramp down	Yes
• intrinsic device protection	Yes
• motor overload protection	Yes; Electronic motor overload protection
• evaluation of thermistor motor protection	No
• auto-RESET	Yes
• manual RESET	Yes
• remote reset	Yes; By turning off the control supply voltage
• communication function	Yes
• operating measured value display	Yes; Only in conjunction with special accessories
• error logbook	Yes; Only in conjunction with special accessories
• via software parameterizable	No
• via software configurable	Yes
• <b>PROFInergy</b>	Yes; in connection with the PROFINET Standard communication module
• voltage ramp	Yes
• torque control	No
• analog output	Yes; 4 ... 20 mA (default) / 0 ... 10 V (parameterizable with High Feature HMI)
<b>Power Electronics</b>	
<b>operational current</b>	
• at 40 °C rated value	210 A
• at 50 °C rated value	186 A
• at 60 °C rated value	170 A
<b>operating voltage</b>	
• rated value	200 ... 480 V
<b>relative negative tolerance of the operating voltage</b>	-15 %
<b>relative positive tolerance of the operating voltage</b>	10 %
<b>operating power for 3-phase motors</b>	
• at 230 V at 40 °C rated value	55 kW
• at 400 V at 40 °C rated value	110 kW
<b>Operating frequency 1 rated value</b>	50 Hz
<b>Operating frequency 2 rated value</b>	60 Hz
<b>relative negative tolerance of the operating frequency</b>	-10 %
<b>relative positive tolerance of the operating frequency</b>	10 %
<b>adjustable motor current</b>	
• at rotary coding switch on switch position 1	90 A
• at rotary coding switch on switch position 2	98 A
• at rotary coding switch on switch position 3	106 A
• at rotary coding switch on switch position 4	114 A
• at rotary coding switch on switch position 5	122 A
• at rotary coding switch on switch position 6	130 A
• at rotary coding switch on switch position 7	138 A
• at rotary coding switch on switch position 8	146 A
• at rotary coding switch on switch position 9	154 A

<ul style="list-style-type: none"> <li>• at rotary coding switch on switch position 10</li> <li>• at rotary coding switch on switch position 11</li> <li>• at rotary coding switch on switch position 12</li> <li>• at rotary coding switch on switch position 13</li> <li>• at rotary coding switch on switch position 14</li> <li>• at rotary coding switch on switch position 15</li> <li>• at rotary coding switch on switch position 16</li> <li>• minimum</li> </ul>	162 A 170 A 178 A 186 A 194 A 202 A 210 A 90 A
<b>minimum load [%]</b>	15 %; Relative to smallest settable le
<b>power loss [W] for rated value of the current at AC</b>	
<ul style="list-style-type: none"> <li>• at 40 °C after startup</li> <li>• at 50 °C after startup</li> <li>• at 60 °C after startup</li> </ul>	16 W 13 W 11 W
<b>power loss [W] at AC at current limitation 350 %</b>	
<ul style="list-style-type: none"> <li>• at 40 °C during startup</li> <li>• at 50 °C during startup</li> <li>• at 60 °C during startup</li> </ul>	2 237 W 1 867 W 1 637 W
<b>type of the motor protection</b>	Electronic, tripping in the event of thermal overload of the motor
<b>Control circuit/ Control</b>	
<b>type of voltage of the control supply voltage</b>	AC/DC
<ul style="list-style-type: none"> <li>• control supply voltage at AC at 50 Hz rated value</li> <li>• control supply voltage at AC at 60 Hz rated value</li> </ul>	24 V 24 V
<b>relative negative tolerance of the control supply voltage at AC at 50 Hz</b>	-20 %
<b>relative positive tolerance of the control supply voltage at AC at 50 Hz</b>	20 %
<b>relative negative tolerance of the control supply voltage at AC at 60 Hz</b>	-20 %
<b>relative positive tolerance of the control supply voltage at AC at 60 Hz</b>	20 %
<b>control supply voltage frequency</b>	50 ... 60 Hz
<b>relative negative tolerance of the control supply voltage frequency</b>	-10 %
<b>relative positive tolerance of the control supply voltage frequency</b>	10 %
<ul style="list-style-type: none"> <li>• control supply voltage at DC rated value</li> </ul>	24 V
<b>relative negative tolerance of the control supply voltage at DC</b>	-20 %
<b>relative positive tolerance of the control supply voltage at DC</b>	20 %
<b>control supply current in standby mode rated value</b>	160 mA
<b>holding current in bypass operation rated value</b>	490 mA
<b>locked-rotor current at close of bypass contact maximum</b>	7.6 A
<b>inrush current peak at application of control supply voltage maximum</b>	3.3 A
<b>duration of inrush current peak at application of control supply voltage</b>	12.1 ms
<b>design of the overvoltage protection</b>	Varistor
<b>design of short-circuit protection for control circuit</b>	4 A gG fuse (I <sub>cu</sub> =1 kA), 6 A quick-acting fuse (I <sub>cu</sub> =1 kA), C1 miniature circuit breaker (I <sub>cu</sub> = 600 A), C6 miniature circuit breaker (I <sub>cu</sub> = 300 A); Is not part of scope of supply
<b>Inputs/ Outputs</b>	
<b>number of digital inputs</b>	1
<b>number of inputs for thermistor connection</b>	0
<b>number of digital outputs</b>	3
<ul style="list-style-type: none"> <li>• not parameterizable</li> </ul>	2
<b>digital output version</b>	2 normally-open contacts (NO) / 1 changeover contact (CO)
<b>number of analog outputs</b>	1
<b>Installation/ mounting/ dimensions</b>	
<b>mounting position</b>	with vertical mounting surface +/-90° rotatable, with vertical mounting

	surface +/- 22.5° tiltable to the front and back
<b>fastening method</b>	screw fixing
<b>height</b>	230 mm
<b>width</b>	160 mm
<b>depth</b>	282 mm
required spacing with side-by-side mounting	
<ul style="list-style-type: none"> <li>• forwards</li> <li>• backwards</li> <li>• upwards</li> <li>• downwards</li> <li>• at the side</li> </ul>	10 mm 0 mm 100 mm 75 mm 5 mm
<b>weight without packaging</b>	7.3 kg
<b>Connections/ Terminals</b>	
<b>type of electrical connection</b>	
<ul style="list-style-type: none"> <li>• for main current circuit</li> <li>• for control circuit</li> </ul>	busbar connection spring-loaded terminals
<b>width of connection bar maximum</b>	45 mm
<b>type of connectable conductor cross-sections</b>	
<ul style="list-style-type: none"> <li>• for main contacts for box terminal using the front clamping point solid</li> </ul>	95 ... 300 mm <sup>2</sup>
<ul style="list-style-type: none"> <li>• for main contacts for box terminal using the front clamping point finely stranded with core end processing</li> </ul>	70 ... 240 mm <sup>2</sup>
<ul style="list-style-type: none"> <li>• for main contacts for box terminal using the front clamping point finely stranded without core end processing</li> </ul>	70 ... 240 mm <sup>2</sup>
<ul style="list-style-type: none"> <li>• for main contacts for box terminal using the front clamping point stranded</li> </ul>	95 ... 300 mm <sup>2</sup>
<ul style="list-style-type: none"> <li>• at AWG cables for main contacts for box terminal using the front clamping point</li> </ul>	3/0 ... 600 kcmil
<ul style="list-style-type: none"> <li>• for main contacts for box terminal using the back clamping point solid</li> </ul>	120 ... 240 mm <sup>2</sup>
<ul style="list-style-type: none"> <li>• at AWG cables for main contacts for box terminal using the back clamping point</li> </ul>	250 ... 500 kcmil
<ul style="list-style-type: none"> <li>• for main contacts for box terminal using both clamping points solid</li> </ul>	min. 2x 70 mm <sup>2</sup> , max. 2x 240 mm <sup>2</sup>
<ul style="list-style-type: none"> <li>• for main contacts for box terminal using both clamping points finely stranded with core end processing</li> </ul>	min. 2x 50 mm <sup>2</sup> , max. 2x 185 mm <sup>2</sup>
<ul style="list-style-type: none"> <li>• for main contacts for box terminal using both clamping points finely stranded without core end processing</li> </ul>	min. 2x 50 mm <sup>2</sup> , max. 2x 185 mm <sup>2</sup>
<ul style="list-style-type: none"> <li>• for main contacts for box terminal using both clamping points stranded</li> </ul>	min. 2x 70 mm <sup>2</sup> , max. 2x 240 mm <sup>2</sup>
<ul style="list-style-type: none"> <li>• for main contacts for box terminal using the back clamping point finely stranded with core end processing</li> </ul>	120 ... 185 mm <sup>2</sup>
<ul style="list-style-type: none"> <li>• for main contacts for box terminal using the back clamping point finely stranded without core end processing</li> </ul>	120 ... 185 mm <sup>2</sup>
<ul style="list-style-type: none"> <li>• for main contacts for box terminal using the back clamping point stranded</li> </ul>	120 ... 240 mm <sup>2</sup>
<b>type of connectable conductor cross-sections</b>	
<ul style="list-style-type: none"> <li>• at AWG cables for main current circuit solid</li> </ul>	2/0 ... 500 kcmil
<ul style="list-style-type: none"> <li>• for DIN cable lug for main contacts stranded</li> </ul>	50 ... 240 mm <sup>2</sup>
<ul style="list-style-type: none"> <li>• for DIN cable lug for main contacts finely stranded</li> </ul>	70 ... 240 mm <sup>2</sup>
<b>type of connectable conductor cross-sections</b>	
<ul style="list-style-type: none"> <li>• for control circuit solid</li> </ul>	2x (0.25 ... 1.5 mm <sup>2</sup> )
<ul style="list-style-type: none"> <li>• for control circuit finely stranded with core end processing</li> </ul>	2x (0.25 ... 1.5 mm <sup>2</sup> )
<ul style="list-style-type: none"> <li>• at AWG cables for control circuit solid</li> </ul>	2x (24 ... 16)
<ul style="list-style-type: none"> <li>• at AWG cables for control circuit finely stranded with core end processing</li> </ul>	2x (24 ... 16)

<b>wire length</b>	
<ul style="list-style-type: none"> <li>• between soft starter and motor maximum</li> <li>• at the digital inputs at AC maximum</li> </ul>	<p>800 m 1 000 m</p>
<b>tightening torque</b>	
<ul style="list-style-type: none"> <li>• for main contacts with screw-type terminals</li> <li>• for auxiliary and control contacts with screw-type terminals</li> </ul>	<p>14 ... 24 N·m 0.8 ... 1.2 N·m</p>
<b>tightening torque [lbf·in]</b>	
<ul style="list-style-type: none"> <li>• for main contacts with screw-type terminals</li> <li>• for auxiliary and control contacts with screw-type terminals</li> </ul>	<p>124 ... 210 lbf·in 7 ... 10.3 lbf·in</p>
<b>Ambient conditions</b>	
installation altitude at height above sea level maximum	5 000 m; Derating as of 1000 m, see manual
<ul style="list-style-type: none"> <li>• ambient temperature during operation</li> <li>• ambient temperature during storage and transport</li> </ul>	<p>-25 ... +60 °C; Please observe derating at temperatures of 40 °C or above -40 ... +80 °C</p>
<b>environmental category</b>	
<ul style="list-style-type: none"> <li>• during operation acc. to IEC 60721</li> <li>• during storage acc. to IEC 60721</li> <li>• during transport acc. to IEC 60721</li> </ul>	<p>3K6 (no ice formation, only occasional condensation), 3C3 (no salt mist), 3S2 (sand must not get into the devices), 3M6 1K6 (only occasional condensation), 1C2 (no salt mist), 1S2 (sand must not get inside the devices), 1M4 2K2, 2C1, 2S1, 2M2 (max. fall height 0.3 m)</p>
<b>EMC emitted interference</b>	acc. to IEC 60947-4-2: Class A
<b>Communication/ Protocol</b>	
<b>communication module is supported</b>	
<ul style="list-style-type: none"> <li>• PROFINET standard</li> <li>• EtherNet/IP</li> <li>• Modbus RTU</li> <li>• Modbus TCP</li> <li>• PROFIBUS</li> </ul>	<p>Yes Yes Yes Yes Yes</p>
<b>UL/CSA ratings</b>	
<b>manufacturer's article number</b>	
<ul style="list-style-type: none"> <li>• of circuit breaker <ul style="list-style-type: none"> <li>— usable for High Faults at 460/480 V according to UL</li> </ul> </li> <li>• of the fuse <ul style="list-style-type: none"> <li>— usable for Standard Faults up to 575/600 V according to UL</li> <li>— usable for High Faults up to 575/600 V according to UL</li> </ul> </li> </ul>	<p>Siemens type: 3VA54, max. 600 A; Iq max = 65 kA Type: Class L, max. 700 A; Iq = 10 kA Type: Class L, max. 700 A; Iq = 100 kA</p>
<b>operating power [hp] for 3-phase motors</b>	
<ul style="list-style-type: none"> <li>• at 200/208 V at 50 °C rated value</li> <li>• at 220/230 V at 50 °C rated value</li> <li>• at 460/480 V at 50 °C rated value</li> </ul>	<p>60 hp 60 hp 150 hp</p>
<b>Safety related data</b>	
<b>protection class IP on the front acc. to IEC 60529</b>	IP00; IP20 with cover
<b>touch protection on the front acc. to IEC 60529</b>	finger-safe, for vertical contact from the front with cover
<b>ATEX</b>	
<b>certificate of suitability</b>	
<ul style="list-style-type: none"> <li>• ATEX</li> <li>• IECEX</li> </ul>	<p>Yes Yes</p>
<b>hardware fault tolerance acc. to IEC 61508 relating to ATEX</b>	0
<b>PFDAvg with low demand rate acc. to IEC 61508 relating to ATEX</b>	0.09
<b>PFHD with high demand rate acc. to EN 62061 relating to ATEX</b>	0.000009 1/h
<b>Safety Integrity Level (SIL) acc. to IEC 61508 relating to ATEX</b>	SIL1
<b>T1 value for proof test interval or service life acc. to</b>	3 y

## Certificates/ approvals

General Product Approval

For use in hazardous locations



Declaration of Conformity

Test Certificates

other



EG-Konf.

[Miscellaneous](#)
[Type Test  
Certificates/Test  
Report](#)
[Type Test  
Certificates/Test  
Report](#)
[Confirmation](#)
[Confirmation](#)

## Further information

Information- and Downloadcenter (Catalogs, Brochures,...)

<https://www.siemens.com/ic10>

Industry Mall (Online ordering system)

<https://mall.industry.siemens.com/mall/en/en/Catalog/product?mlfb=3RW5072-2AB04>

Cax online generator

<http://support.automation.siemens.com/WW/CAXorder/default.aspx?lang=en&mlfb=3RW5072-2AB04>

Service&amp;Support (Manuals, Certificates, Characteristics, FAQs,...)

<https://support.industry.siemens.com/cs/ww/en/ps/3RW5072-2AB04>

Image database (product images, 2D dimension drawings, 3D models, device circuit diagrams, EPLAN macros, ...)

[http://www.automation.siemens.com/bilddb/cax\\_de.aspx?mlfb=3RW5072-2AB04&lang=en](http://www.automation.siemens.com/bilddb/cax_de.aspx?mlfb=3RW5072-2AB04&lang=en)
Characteristic: Tripping characteristics, I<sup>2</sup>t, Let-through current
<https://support.industry.siemens.com/cs/ww/en/ps/3RW5072-2AB04/char>

Characteristic: Installation altitude

<http://www.automation.siemens.com/bilddb/index.aspx?view=Search&mlfb=3RW5072-2AB04&objecttype=14&gridview=view1>

Simulation Tool for Soft Starters (STS)

<https://support.industry.siemens.com/cs/ww/en/view/101494917>

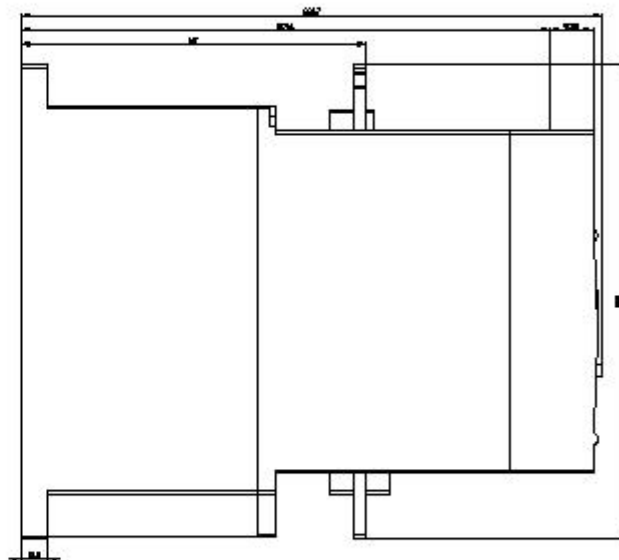
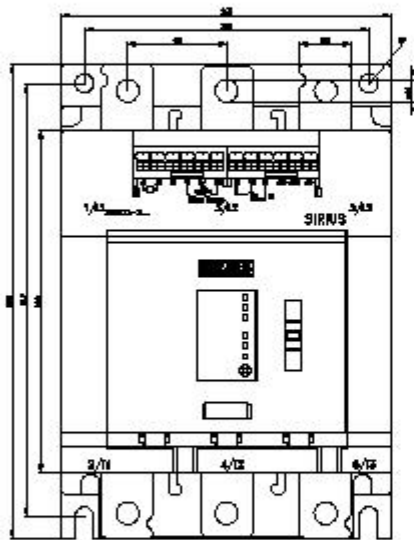

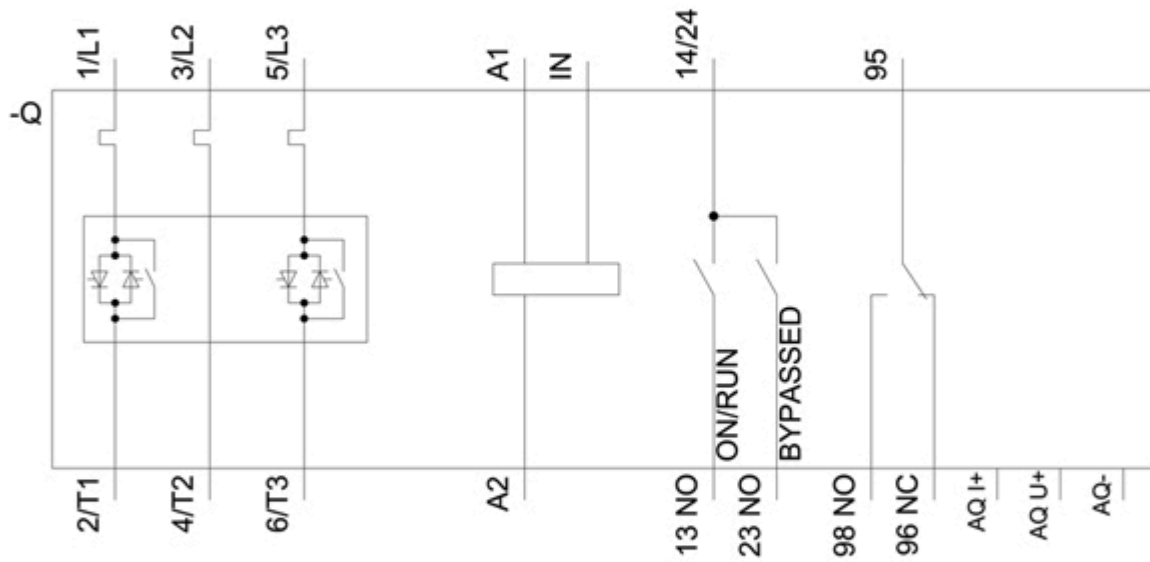

last modified:

12/15/2020 